

# Installation Manual

## 740/741

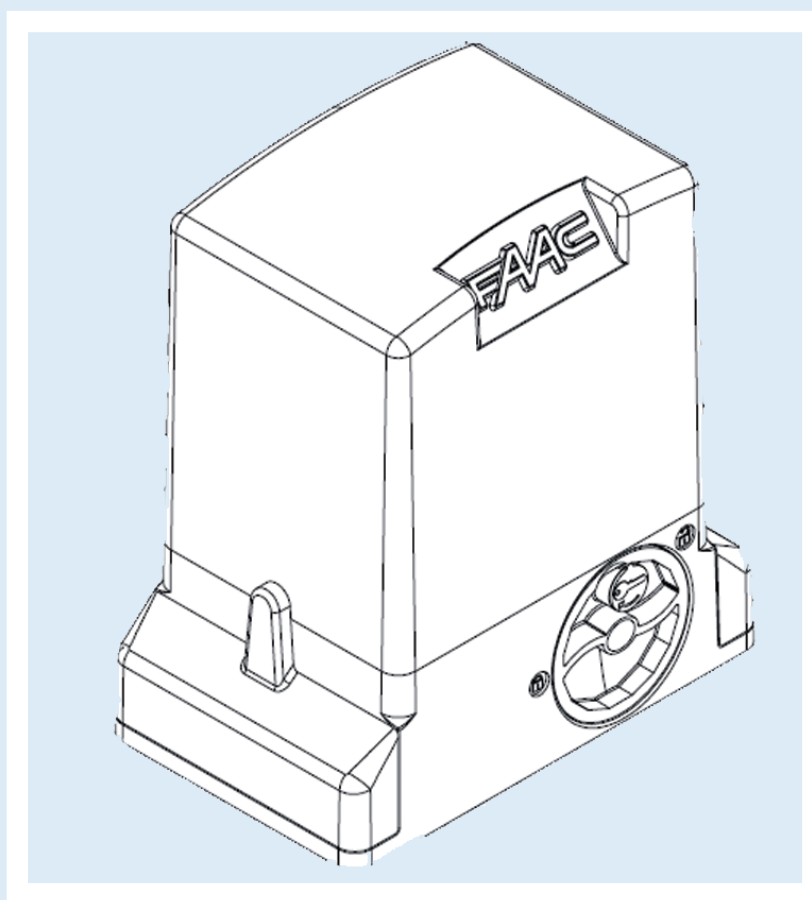

## Sliding Gate System

**FAAC**

Leading the way ...



# EC DECLARATION OF CONFORMITY FOR MACHINES

(DIRECTIVE 98/37/EC)

**Manufacturer:** FAAC S.p.A.

**Address:** Via Benini, 1 - 40069 Zola Predosa BOLOGNA - ITALY

**Declares that:** 740 / 741 mod. operator with electronic control unit 740D

- is built to be integrated into a machine or to be assembled with other machinery to create a machine under the provisions of Directive 98/37/EC;
- conforms to the essential safety requirements of the following EEC directives:

73/23/EEC and subsequent amendment 93/68/EEC.  
89/336/EEC and subsequent amendment 92/31/EEC and 93/68/EEC

and also declares that it is prohibited to put into service the machinery until the machine in which it will be integrated or of which it will become a component has been identified and declared as conforming to the conditions of Directive 98/37/EC.

Bologna, 01 January 2004

The Managing Director

A. Bassi

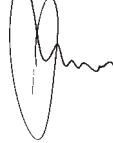

## WARNINGS FOR THE INSTALLER

### GENERAL SAFETY OBLIGATIONS

- 1) ATTENTION! To ensure the safety of people, it is important that you read all the following instructions. Incorrect installation or incorrect use of the product could cause serious harm to people.**
- 2) Carefully read the instructions before beginning to install the product.
- 3) Do not leave packing materials (plastic, polystyrene, etc.) within reach of children as such materials are potential sources of danger.
- 4) Store these instructions for future reference.
- 5) This product was designed and built strictly for the use indicated in this documentation. Any other use, not expressly indicated here, could compromise the good condition/operation of the product and/or be a source of danger.
- 6) FAAC declines all liability caused by improper use or use other than that for which the automated system was intended.
- 7) Do not install the equipment in an explosive atmosphere: the presence of inflammable gas or fumes is a serious danger to safety.
- 8) The mechanical parts must conform to the provisions of Standards EN 12604 and EN 12605.  
For non-EU countries, to obtain an adequate level of safety, the Standards mentioned above must be observed, in addition to national legal regulations.
- 9) FAAC is not responsible for failure to observe Good Technique in the construction of the closing elements to be motorised, or for any deformation that may occur during use.
- 10) The installation must conform to Standards EN 12453 and EN 12445.  
For non-EU countries, to obtain an adequate level of safety, the Standards mentioned above must be observed, in addition to national legal regulations.
- 11) Before attempting any job on the system, cut out electrical power .
- 12) The mains power supply of the automated system must be fitted with an all-pole switch with contact opening distance of 3mm or greater. Use of a 6A thermal breaker with all-pole circuit break is recommended.
- 13) Make sure that a differential switch with threshold of 0.03 A is fitted upstream of the system.
- 14) Make sure that the earthing system is perfectly constructed, and connect metal parts of the means of the closure to it.
- 15) The automated system is supplied with an intrinsic anti-crushing safety device consisting of a torque control. Nevertheless, its tripping threshold must be checked as specified in the Standards indicated at point 10.
- 16) The safety devices (EN 12978 standard) protect any danger areas against **mechanical movement Risks**, such as crushing, dragging, and shearing.
- 17) Use of at least one indicator-light (e.g. FAACLIGHT) is recommended for every system, as well as a warning sign adequately secured to the frame structure, in addition to the devices mentioned at point "16".
- 18) FAAC declines all liability as concerns safety and efficient operation of the automated system, if system components not produced by FAAC are used.
- 19) For maintenance, strictly use original parts by FAAC.
- 20) Do not in any way modify the components of the automated system.
- 21) The installer shall supply all information concerning manual operation of the system in case of an emergency, and shall hand over to the user the warnings handbook supplied with the product.
- 22) Do not allow children or adults to stay near the product while it is operating.
- 23) Keep remote controls or other pulse generators away from children, to prevent the automated system from being activated involuntarily.
- 24) Transit is permitted only when the automated system is idle.
- 25) The user must not attempt any kind of repair or direct action whatever and contact qualified personnel only.
- 26) Maintenance: check at least every 6 months the efficiency of the system, particularly the efficiency of the safety devices (including, where foreseen, the operator thrust force) and of the release devices.
- 27) Anything not expressly specified in these instructions is not permitted.**

# AUTOMATED SYSTEM 740-741

These instructions apply to the following models:

## FAAC 740 - 741

The 740-741 gearmotor is an electro-mechanical operator designed for moving sliding gates.

The non-reversing reduction system ensures the gate is mechanically locked when the gearmotor is not operating, therefore it is not necessary to install any electric lock

A convenient manual release with customised key makes it possible to move the gate in the event of a power failure or malfunction of the operator.

**The 740-741 gearmotor was designed and built for controlling vehicle access. AVOID ANY OTHER USE WHATEVER.**

## 1. DESCRIPTION AND TECHNICAL SPECIFICATIONS

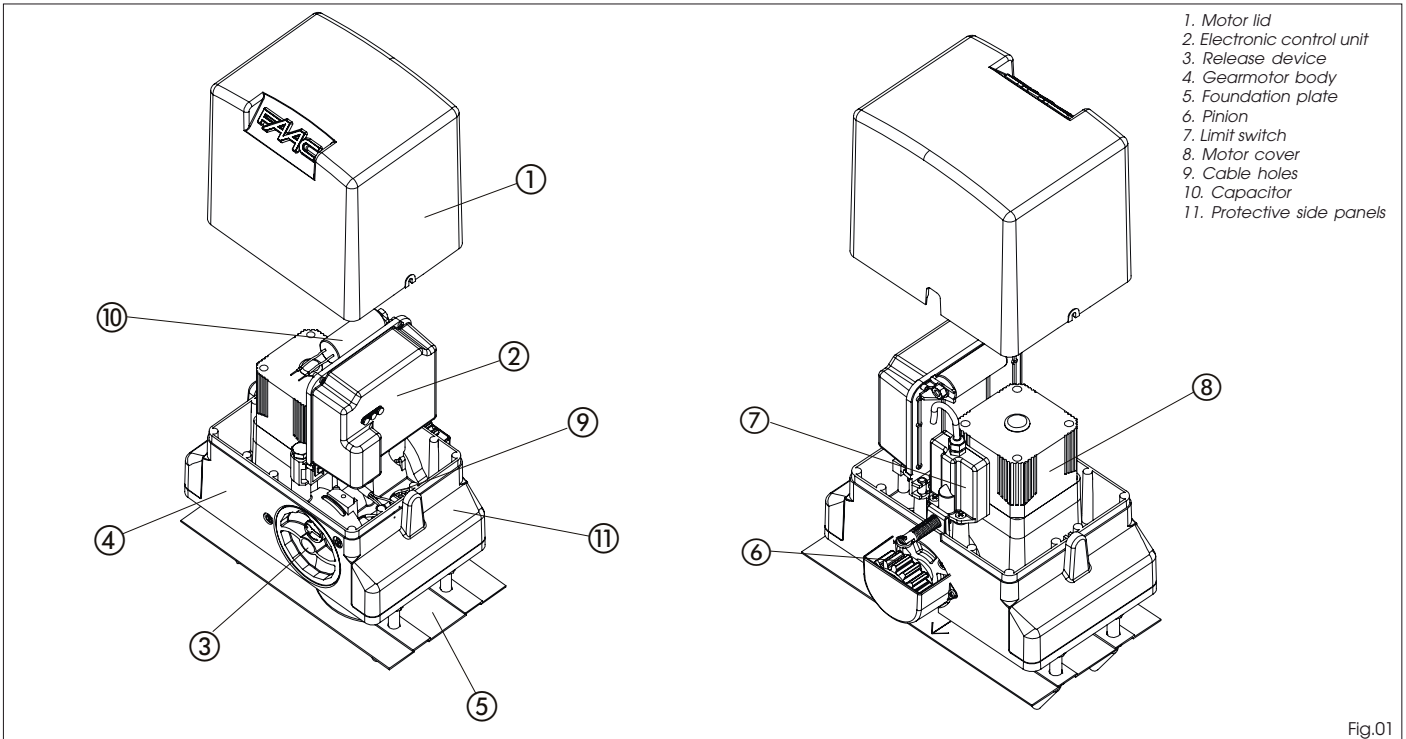

Fig.01

MODEL	740	741
Power supply (+6% -10%)	230 V ~ 50Hz	230 V ~ 50Hz
Absorbed power (W)	350	500
Absorbed current (A)	1.5	2.2
Capacitor (μF)	10	12.5
Thrust on pinion (daN)	45	65
Torque (Nm)	18	24
Winding thermal protection (°C)	140	140
Leaf max weight (Kg)	500	900
Type of pinion	Z16	Z16
Gate speed (m/min)	12	12
Gate max length (m)	15	15
Type of limit switch	Mechanical	Mechanical
Clutch	Electronic	Electronic
Use frequency	S3 - 30%	S3 - 40%
Operating temperature (°C)	-20 +55	-20 +55
Gearmotor weight (Kg)	10	11
Protection class	IP44	IP44
Gearmotor overall dimensions	See Fig.02	See Fig.02

## 2. DIMENSIONS

Values are expressed in mm

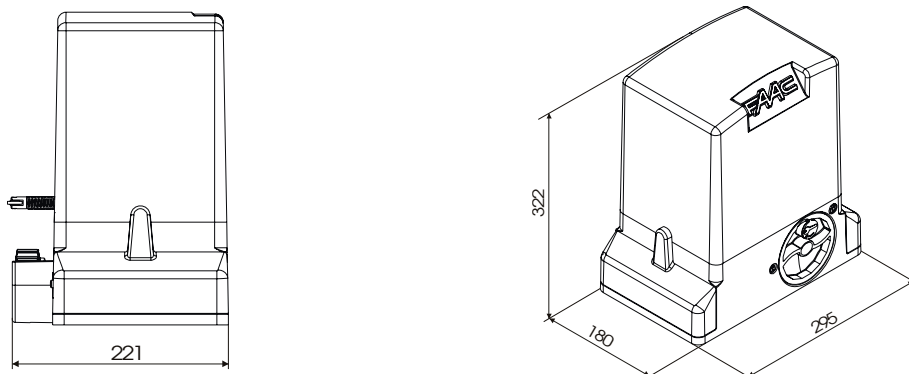

Fig.02

### 3. MAXIMUM USE CURVE

The curve makes it possible to establish maximum work time (T) according to use frequency (F). With reference to IEC 34-1 Standard, the 740-741 gearmotor with an S3 duty, can operate at a use frequency of 30-40%.

To ensure efficient operation, it is necessary to operate in the work range below the curve.

**Important:** the curve is obtained at a temperature of 20°C.

Exposure to the direct sun rays can reduce frequency down to 20%

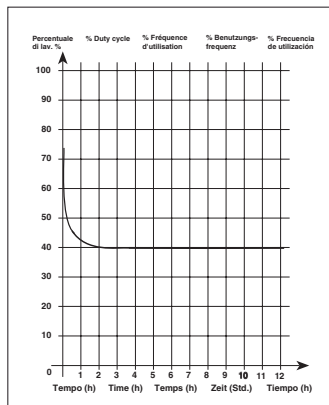

#### Calculation of use frequency

Use frequency is the percentage of effective work time (opening + closing) compared to total time of cycle (opening + closing + pause times).

Calculation formula:

$$\% F = \frac{Ta + Tc}{Ta + Tc + Tp + Ti} \times 100$$

where:

Ta = opening time

Tc = closing time

Tp = pause time

Ti = time of interval between two complete cycles

### 4. ELECTRICAL SET-UP (standard system)

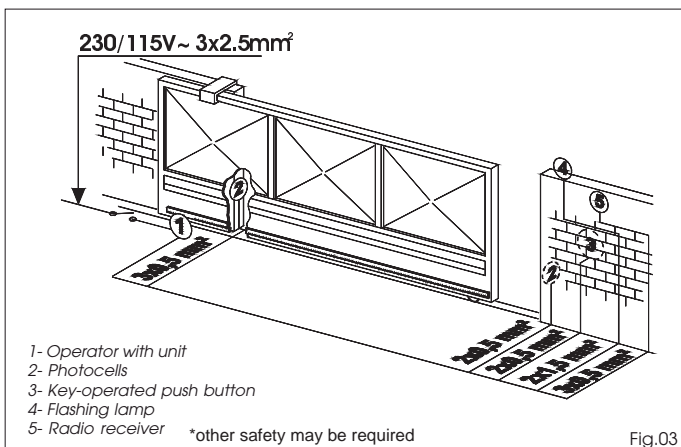

### 5. INSTALLING THE AUTOMATED SYSTEM

#### 5.1. Preliminary checks

To ensure safety and efficiency of the automated system, make sure the following requirements are observed before installing the system:

- The gate structure must be suitable for automation. The following are necessary in particular: wheel diameter must be in proportion to the weight of the gate, an upper track must be provided, plus mechanical travel stops to prevent the gate derailing.
- The ground must guarantee a perfect stability of the foundation plinth.
- There must be no pipes or electric cables in the plinth excavation area.
- If the gearmotor is located in the vehicle transit or manoeuvre area, adequate means of protection should be provided against accidental impact.
- Check if an efficient earthing is available for connection to the gearmotor.

#### 5.2. Masonry for foundation plate

- 1- Assemble the foundation plate as shown in figure 04.
- 2- In order to ensure that the pinion and rack engage correctly, the foundation plate must be positioned as shown in Fig. 05 (right closing) or Fig. 06 (left closing).

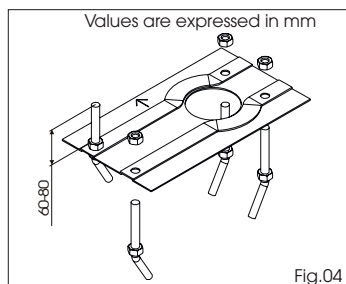

**Warning:** The arrow on the foundation plate must always point to the gate, see Figs 05-06.

3- After determining the position of the foundation plate, make a plinth as shown in Fig. 07 and wall the plate, providing several sheaths for routing the cables. Using a spirit level, check if the plate is perfectly level. Wait for the cement to set.

4- Lay the electric cables for connection to the accessories and power supply as shown in diagram of Fig. 03. To facilitate connections to the control unit, allow the cables to protrude by at least 50 cm from the hole on the foundation plate.

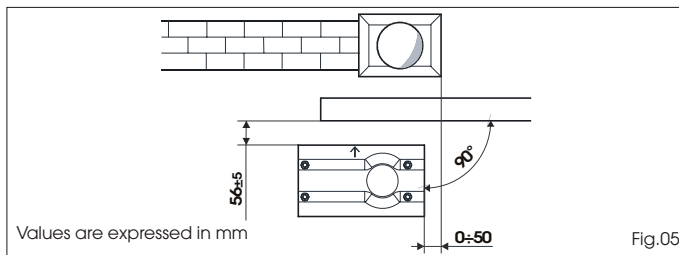

Fig.05

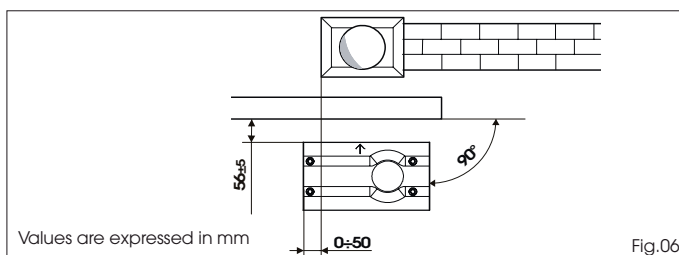

Fig.06

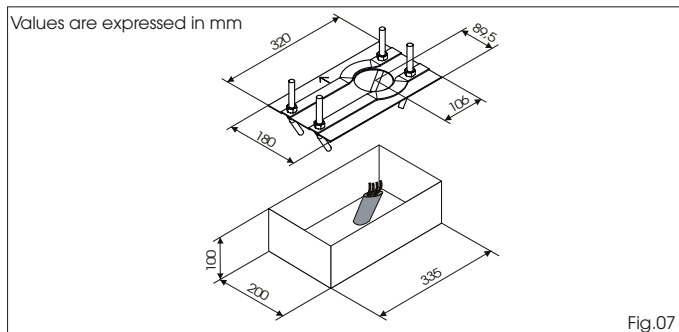
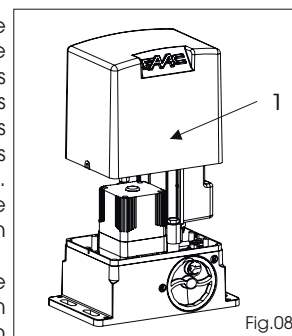

Fig.07

#### 5.3. Mechanical installation

- 1- Remove the cover, Fig. 08 ref. 1.
- 2- Position the operator on the foundation plate, using the supplied washers and nuts as shown in Fig. 09. During this operation, route the cables through the appropriate openings in the motor body (See Fig.01 ref.9). If necessary, the two holes can be joined using a hammer to obtain a wider space.
- 3- Adjust the height of the gearmotor and the distance from the gate, referring to dimensions in Fig. 10.



**Attention:** This operation is necessary to ensure the rack is correctly secured and to enable any new adjustments.

- 4- Secure the gearmotor to the plate, tightening the nuts.
- 5- Prepare the operator for manual operation as described in paragraph 8.

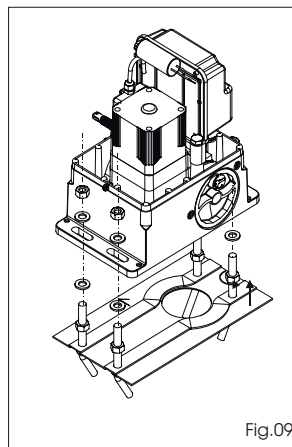
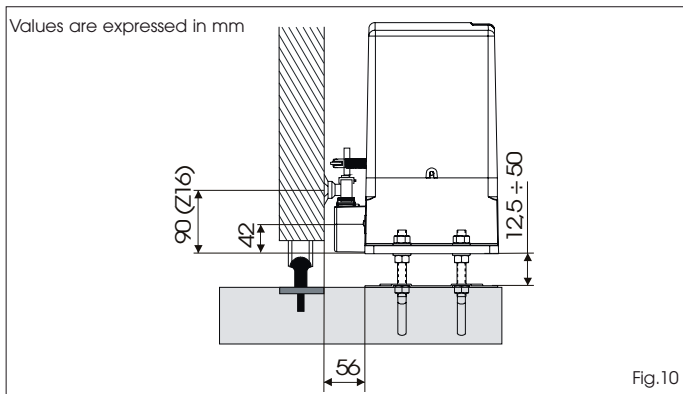

Fig.09



## 5.4. Assembling the rack

### 5.4.1. Steel rack to weld (Fig. 11)

- 1) Fit the three threaded pawls on the rack element, positioning them at the bottom of the slot. In this way, the slot play will enable any future adjustments to be made.
- 2) Manually take the leaf into its closing position.
- 3) Lay the first section of rack level on the pinion and weld the threaded pawl on the gate as shown in Fig. 13.
- 4) Move the gate manually, checking if the rack is resting on the pinion, and weld the second and third pawl.
- 5) Position another rack element end to end with the previous one, using a section of rack (as shown in Fig. 14) to synchronise the teeth of the two elements.
- 6) Move the gate manually and weld the three threaded pawls, thus proceeding until the gate is fully covered.

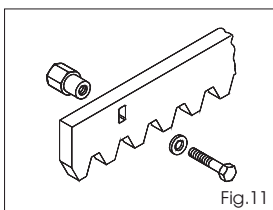

### 5.4.2. Steel rack to screw (Fig. 12)

- 1) Manually take the leaf into its closing position.
- 2) Lay the first section of rack level on the pinion and place the spacer between the rack and the gate, positioning it at the bottom of the slot.
- 3) Mark the drilling point on the gate. Drill a  $\varnothing$  6,5 mm hole and thread with an M8 male tap. Screw the bolt.
- 4) Move the gate manually, checking if the rack is resting on the pinion, and repeat the operations at point 3.
- 5) Position another rack element end to end with the previous one, using a section of rack (as shown in figure 14) to synchronise the teeth of the two elements.
- 6) Move the gate manually and carry out the securing operations as for the first element, thus proceeding until the gate is fully covered.

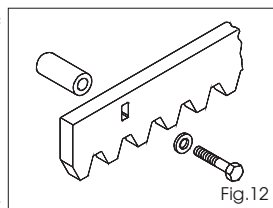

## Notes on rack installation

- Make sure that, during the gate travel, all the rack elements do not exit the pinion.
- **Do not, on any account, weld the rack elements either to the spacers or to each other.**
- When the rack has been installed, to ensure it meshes correctly with the pinion, it is advisable to lower the gearmotor position by about 1.5 mm (Fig.15).
- Manually check if the gate correctly reaches the mechanical limit stops maintaining the pinion and rack coupled and make sure there is no friction during gate travel.
- Do not use grease or other lubricants between rack and pinion.

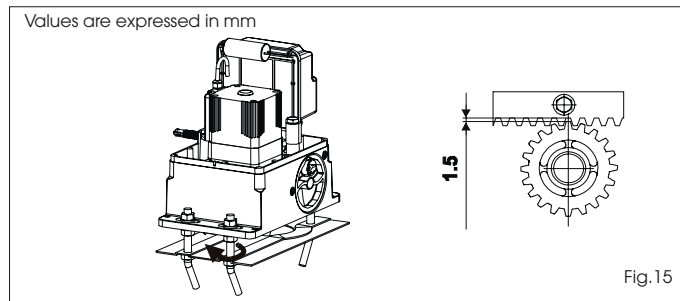
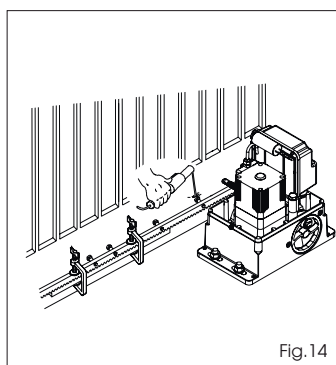
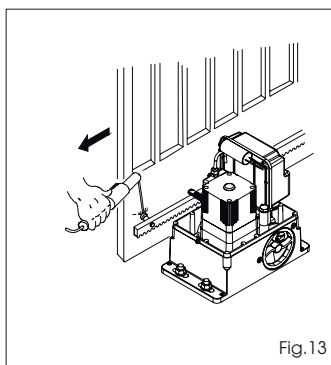

## 6. START-UP

### 6.1. Control board connection

**Before attempting any work on the board (connections, programming, maintenance), always turn off power.**

Follow points 10, 11, 12, 13 and 14 of the GENERAL SAFETY OBLIGATIONS.

Following the instructions in Fig. 3, route the cables through the raceways and make the necessary electric connections to the selected accessories.

Always separate power cables from control and safety cables (push-button, receiver, photocells, etc.). To avoid any electric noise whatever, use separate sheaths.

#### 6.1.1. Earthing

Connect the earth cables as shown in Fig.16 ref.A.

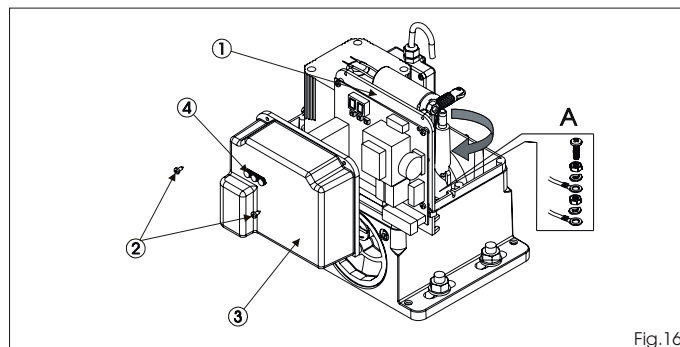

#### 6.1.2. Electronic control unit

In the gearmotors, the electronic control unit is fitted to an adjustable support (Fig. 16 ref. 1) with transparent lid (Fig. 16 ref. 3).

The board programming push buttons (Fig. 16 ref. 4) have been located on the lid. This allow the board to be programmed without removing the lid.

For correct connection of the control unit, follow indications the specific instructions:

### 6.2. Positioning the limit switches

The operator has a mechanical travel stop with spring-lever, which commands gate movement to stop when a profiled steel plate, secured on the top of the rack, activates the spring until the microswitch is tripped. The plate support can be fitted to all racks with max. width of 13 mm.

Procedure for correct positioning of the two travel stop plates supplied:

- 1) Fit and secure the 2 profiled steel plates on the 2 U-supports, using the supplied nuts and washers, as shown in figure 17.
- 2) Prepare the operator for manual operation as described in paragraph 8.
- 3) Power up the system.
- 4) Securing the opening limit switch: manually take the gate to opening position, leaving 20 mm from the mechanical travel stop.
- 5) Allow the plate to slide over the rack in opening direction (Fig.18). As soon as the opening limit switch LED on the control board goes off, take the plate forward by about 20÷30 mm and secure it provisionally on the rack, using the supplied screws.
- 6) Repeat the operations at points 4 and 5 for the closing limit switch, Fig. 19.

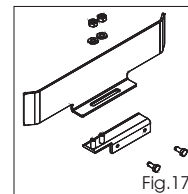

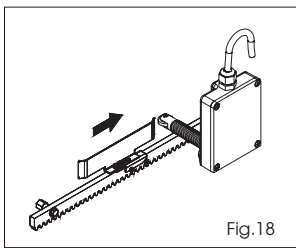

Fig. 18

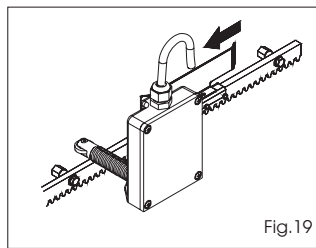

Fig. 19

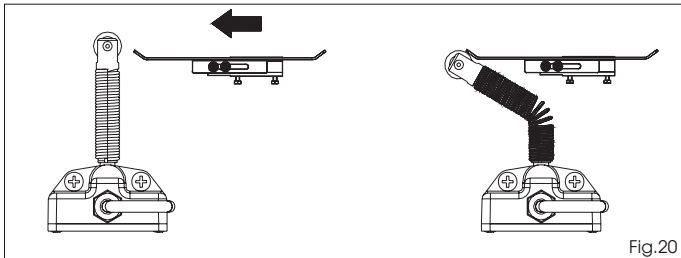

Fig. 20

**Important:**

- a) The plate must activate the limit-switch on the profiled part as shown in figure 20.
- b) If the wheel and the travel stop plate are too close, it may be necessary to shorten the limit-switch spring by a couple of turns. Procedure for shortening the spring:
  - To remove the spring, turn it anticlockwise. This operation requires some force.
  - Shorten the spring as shown in Fig. 22: two turns correspond to about 3 mm.
  - Fit the spring turning it clockwise, Fig. 23, until the stop is reached; see Fig. 24.
  - Once the spring is back in place, ensure the wheel is horizontal. A wrong wheel orientation may jeopardise the operation of the limit switches.

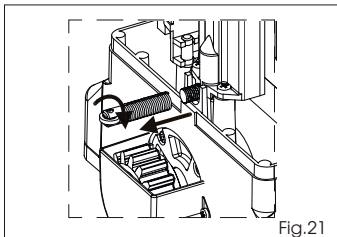
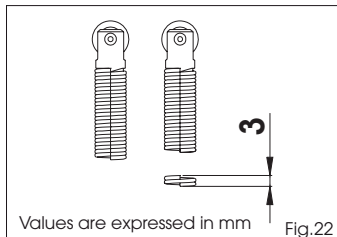

Fig. 21



Values are expressed in mm Fig. 22

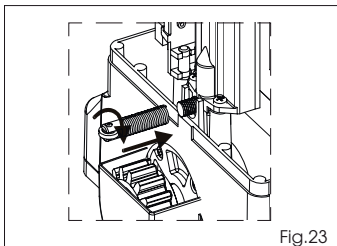

Fig. 23

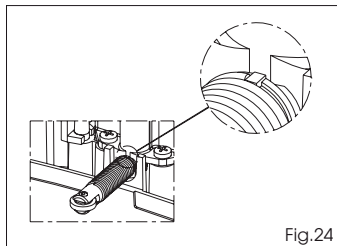

Fig. 24

8) Re-lock the system (see paragraph 9).

**Important: Before sending a pulse, make sure that the gate cannot be moved manually.**

9) Command a complete gate cycle to check if the limit switch is tripped correctly.

**Warning: To avoid damaging the operator and/or interrupting operation of the automated system, allow a space of about 20mm from the mechanical travel stops.**

10) Appropriately adjust the position of the travel stop plates and definitively secure them on the rack.

**7. TESTING THE AUTOMATED SYSTEM**

After installing the operator, carefully check operating efficiency of all accessories and safety devices connected to it.

Return the board support to its original position. Fit the cover (Fig. 25 ref. 1), tighten the two side screws provided (Fig. 25 ref 2) and snap-fit the side panels (Fig. 25 ref.3).

Apply the danger sticker on the top of the cover (Fig. 26).

Hand the "User's Guide" to the Customer and explain correct operation and use of the gearmotor, indicating the potentially dangerous areas of the automated system.

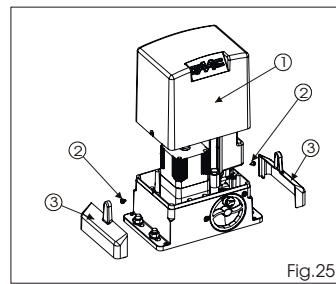

Fig. 25

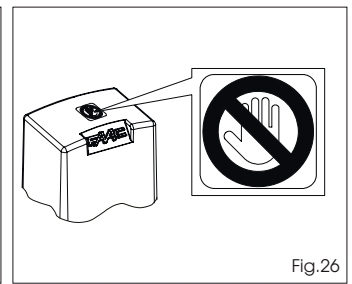

Fig. 26

**8. MANUAL OPERATION**

**Warning: Cut power to the system to prevent an involuntary pulse from activating the gate during the release manoeuvre.**

To release the operator proceed as follows:

- 1) Insert the key provided and turn it clockwise as shown in Fig. 27 ref. 1 and 2.
- 2) Turn the release system clockwise, until the mechanical stop is reached, Fig. 27 ref. 3.
- 3) Open and close the gate manually.

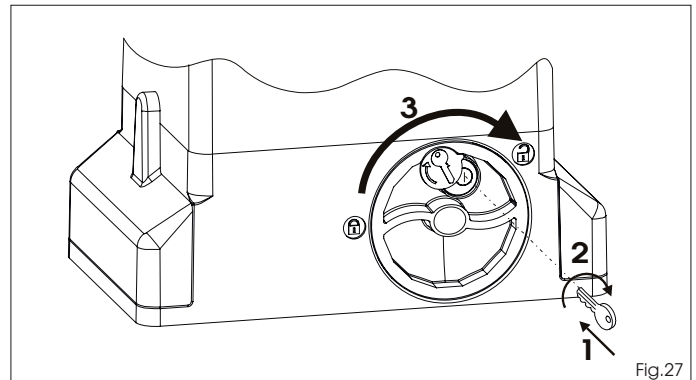

Fig. 27

**9. RESTORING NORMAL OPERATION**

**Warning: Cut power to the system to prevent an involuntary pulse from activating the gate during the manoeuvre for restoring normal operation.**

To restore normal operation proceed as follows:

- 1) Turn the release system anti-clockwise, until its stop is reached, Fig. 28 ref. 1.
- 2) Turn the key anti-clockwise and remove it from the lock, Fig. 28 ref. 2 and 3.
- 3) Move the gate until the release system meshes (corresponds to gate locking)
- 4) Power up the system.

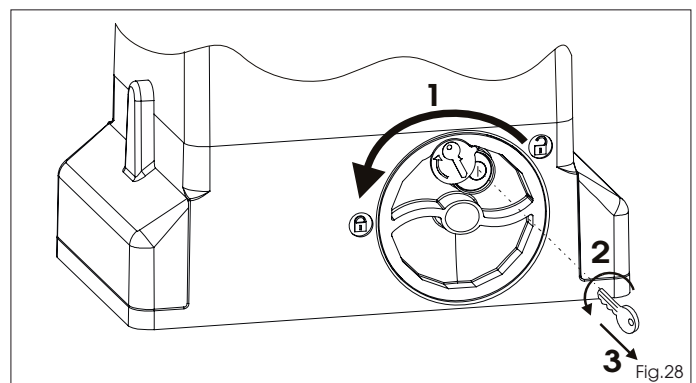

Fig. 28

**10. SPECIAL APPLICATIONS**

There are no special applications.

**11. MAINTENANCE**

Check the operational efficiency of the system at least once every 6 months, especially as regards the efficiency of the safety and release devices (including operator thrust force).

**12. REPAIRS**

For any repairs, contact the authorised Repair Centres.

**13. AVAILABLE ACCESSORIES**

Refer to the catalogue for available accessories.

# CONTROL BOARD 740D

## 1. WARNINGS

**Important:** Before attempting any work on the control board (connections, maintenance), always turn off power.

- Install, upstream of the system, a differential thermal breaker with adequate tripping threshold.
- Connect the earth cable to the appropriate terminal on the J7 connector of the equipment (see fig. 30).
- Always separate power cables from control and safety cables (push-button, receiver, photocells, etc.). To avoid any electric noise, use separate sheaths or a shielded cable (with earthed shield).

## 2. TECHNICAL SPECIFICATIONS

Model	740D-115V	740D-230V
Power supply V~ (+6% -10%) 50 Hz	115	230
Absorbed power (W)	10	10
Motor max. load (W)	1200	1000
Accessories max. load (A)	0.5	0.5
Operating ambient temperature	-20 °C +55 °C	
Protection fuses	2 (see fig. 29)	
Function logics: Automatic / "Stepped" automatic / Semi-automatic / Safety devices / Semi-automatic B / Dead-man C / "Stepped" semi-automatic / Mixed B/C logic		
Work time	Programmable (from 0 to 4 min.)	
Pause time	Programmable (from 0 to 4 min.)	
Thrust force	Adjustable over 50 levels	
Terminal board inputs	Open / partial opening / Safety devices at opng. / Safety devices at clsg. / Stop / Edge / Power supply + Earth	
On-connector inputs	Opening and closing limit-switches / Encoder optional	
Terminal board outputs	Flashing lamp - Motor - 24 Vdc accessories power supply - 24 Vdc indicator-light / Timed output. - Fail safe	
Rapid connector	5-pin card connection for Minidec, Decoder or RP receivers	
Programming	3 keys (+, -, F) and display, "basic" or "advanced" mode	
Basic mode programmable functions	Function logic - Pause time - Thrust Force - Gate direction	
Advanced mode programmable functions:	Torque at initial thrust - Braking - Fail safe-Pre-flashing - Indicator-light/Timed output/Electric lock or 'traffic lights' command - Opening and closing safety devices logic - Encoder/ Anti-crushing sensitivity - Decelerations - Partial opening time - Work time - Assistance request - Cycle counter	

## 4. ELECTRIC CONNECTIONS

## 3. LAYOUT AND COMPONENTS

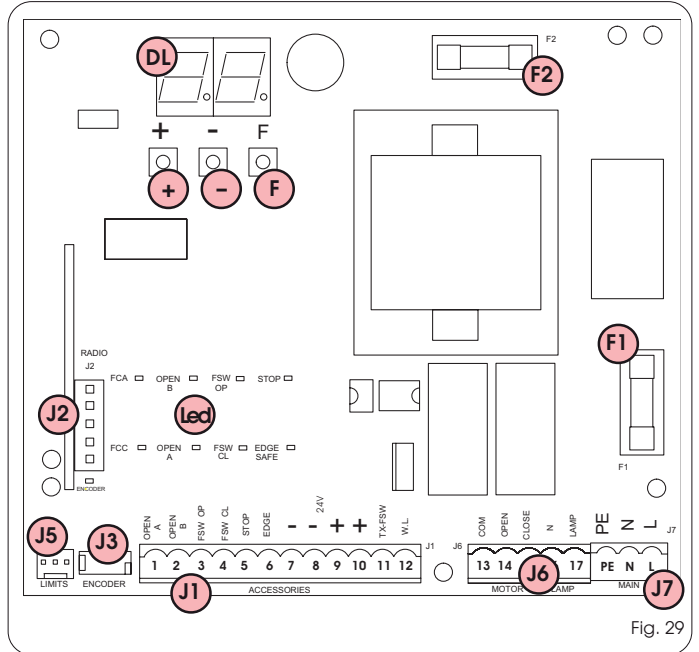

Fig. 29

DL	SIGNALLING AND PROGRAMMING DISPLAY
Led	INPUTS STATUS CONTROL LED
J1	LOW VOLTAGE TERMINAL BOARD
J2	CONNECTOR FOR DECODER/MINIDEC/RP RECEIVER
J3	ENCODER CONNECTOR
J5	LIMIT -SWITCH CONNECTOR
J6	MOTORS AND FLASHING LAMP CONNECTION TERMINAL BOARD
J7	POWER SUPPLY TERMINAL BOARD 115V <sub>ac</sub> (740D-115V)-230V <sub>ac</sub> (740D-230V)
F1	MOTORS AND TRANSF. PRIMARY FUSE (740D 115V=F10A - 740D 230V=F 5A)
F2	LOW VOLTAGE AND ACCESSORIES FUSE (T 800mA)
F	"F" PROGRAMMING PUSH-BUTTON
-	"-" PROGRAMMING PUSH-BUTTON
+	"+" PROGRAMMING PUSH-BUTTON

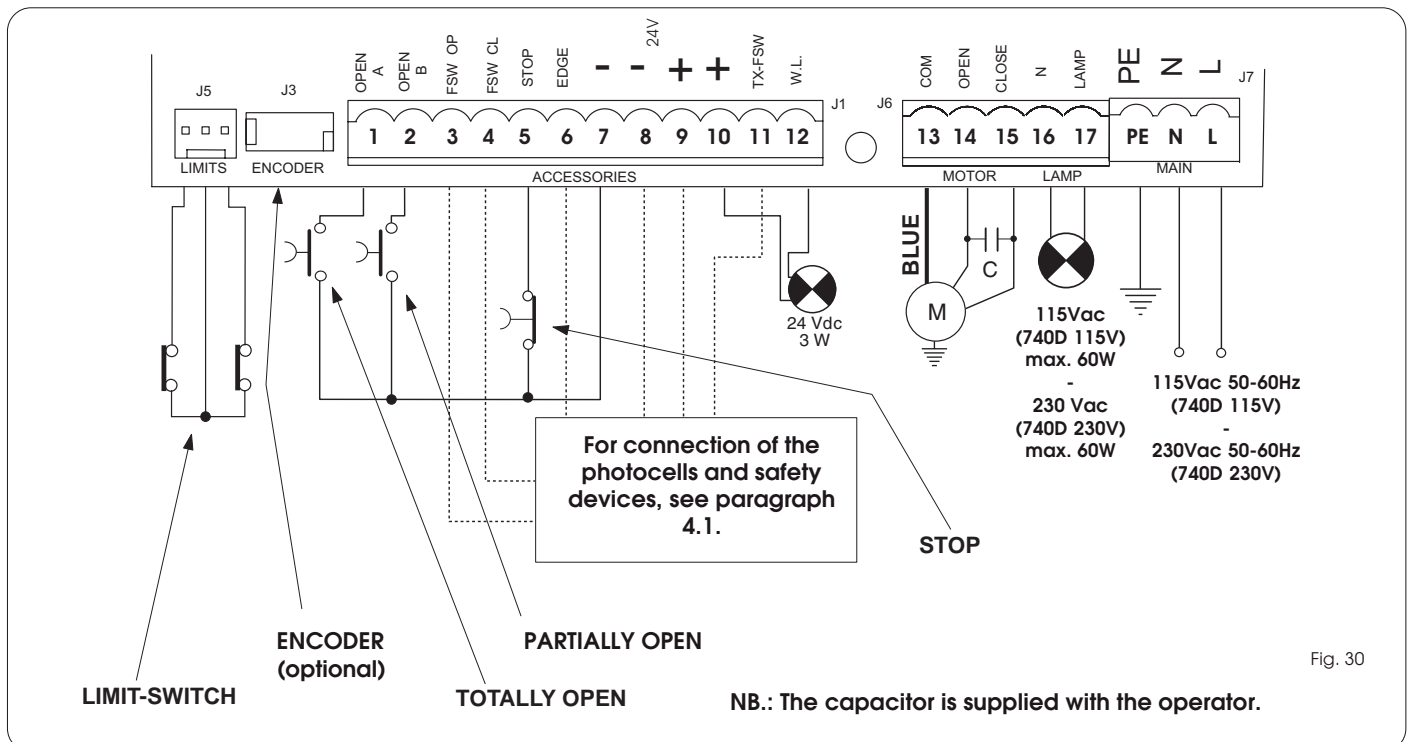

Fig. 30

#### 4.1. Connection of photocells and safety devices

Before connecting the photocells (or other devices) we advise you to select the type of operation according to the movement area they have to protect (see fig. 31):

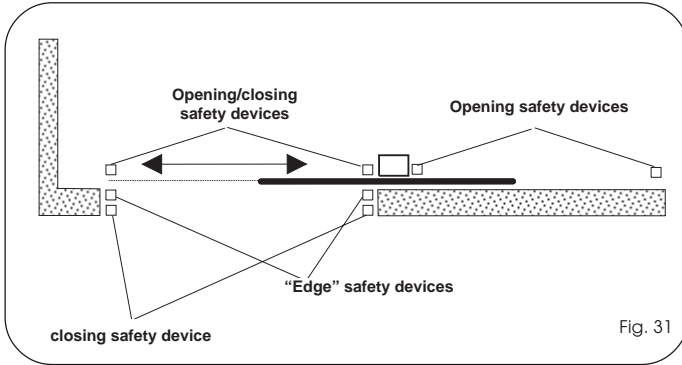

Fig. 31

**Opening safety devices:** they are tripped when an obstacle is detected only during gate opening movement. They cause immediate closure and resumption of opening motion on release (see programming in par 5.2).

**Closing safety devices:** they are tripped when an obstacle is detected only during gate closing movement. They cause re-opening, either immediate or on release (see programming in par 5.2).

**Opening/closing safety devices:** they are tripped during the gate opening and closing movements. They cause stopping and restart motion on release.

**"Edge" safety devices:** they are tripped during the gate opening and closing movements, They cause immediate reversal of motion and stopping after two seconds.

**Encoder:** it is tripped if there is an obstacle during gate opening and closing movements. It causes immediate reversal of motion and stopping after two seconds. (optional)

**N.B.** If two or more safety devices have the same function (opening, closing, opening and closing, edge), the contacts must be connected to each other in series (fig. 32).

**N.C.** contacts must be used.

Connection of two N.C. contacts in series  
(e.g. Photocells, Stop, Edge, etc.)



Fig. 32

**N.B.** If safety devices are not used, jumper connect the terminals as shown in fig. 33.

Connection of no safety device

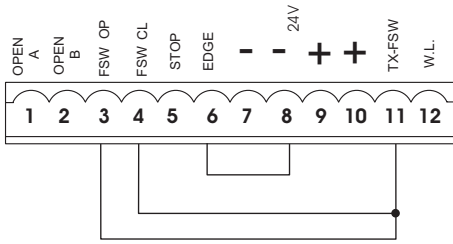

Fig. 33

The most common photocell and safety device lay-outs are shown below (from fig. 34 to fig. 41).

Connection of a closing safety device and an opening safety device

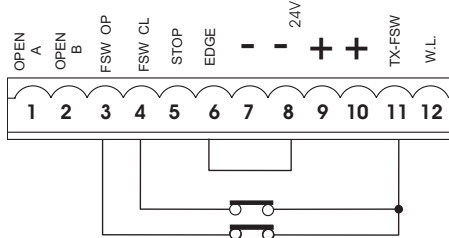

Fig. 34

Connection of an "edge" safety device

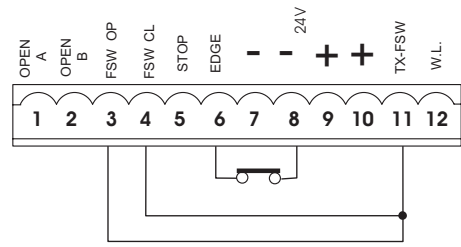

Fig. 35

Connection of a pair of photocells for opening

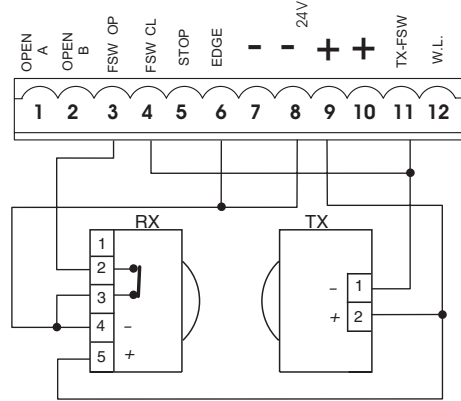

Fig. 36

Connection of a pair of closing photocells

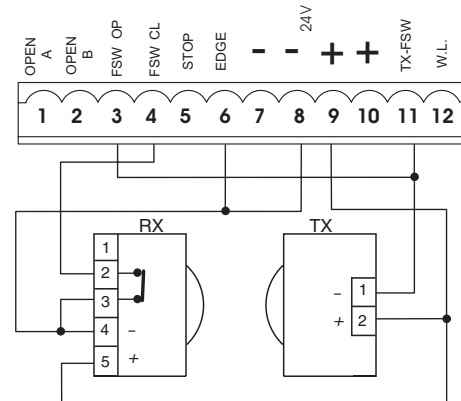

Fig. 37

Connection of a pair of opening photocells, a pair of closing photocell and an edge safety device

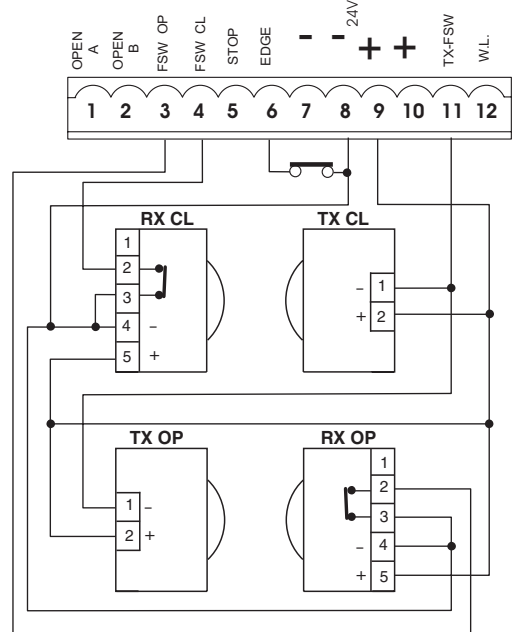

Fig. 38



Connection of two pairs of closing photocells and two edge safety devices

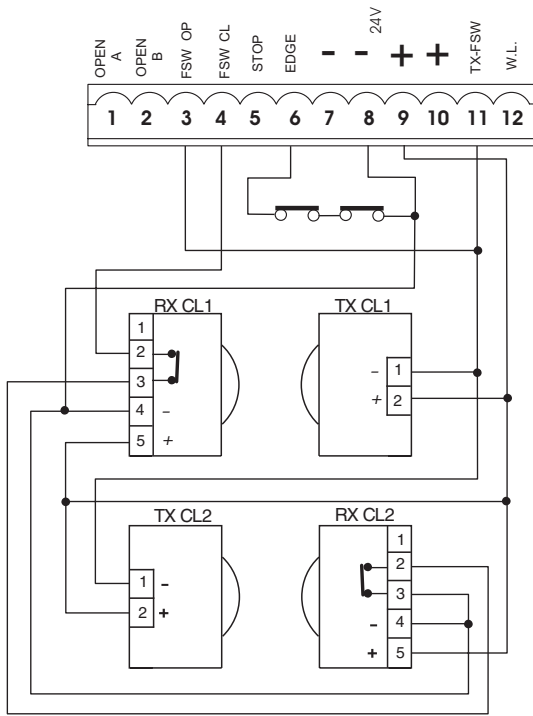

Fig. 39

Connection of a pair of closing photocells and a pair of opening/closing photocells

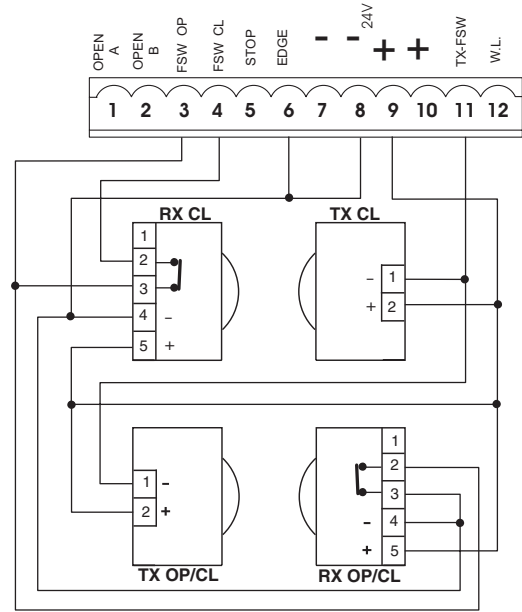

Fig. 41

Connection of a pair of closing photocells, a pair of opening photocells and a pair of opening/closing photocells

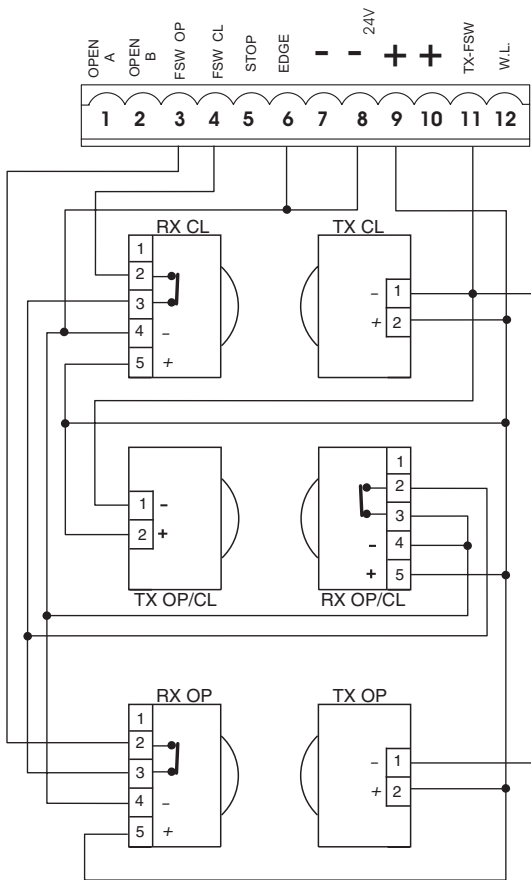

Fig. 40

Connection of two N.O. contacts in parallel (e.g. Open A, Open B)

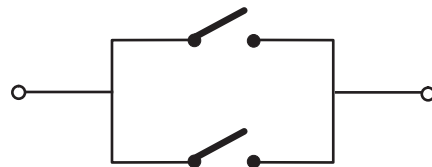

Fig. 42

#### 4.2. J7 Terminal board - Power supply (fig. 30)

##### POWER SUPPLY (terminals PE-N-L):

- PE: Earth connection
- N : Power supply ( Neutral )
- L : Power supply ( Line )

**NB.:** For correct operation, the board must be connected to the earth conductor in the system. Install an adequate differential thermal breaker upstream of the system.

#### 4.3. J6 Terminal board - Motors and flashing lamp (fig. 30)

##### MOTOR - (terminals 13-14-15): Motor connection.

In gearmotors with a built-in control unit, this connection is pre-wired standard. For leaf opening direction, see basic programming in par. 5.1.

##### LAMP - (terminals 16 -17): Flashing lamp output.

#### 4.4. J1 Terminal board - Accessories (fig. 30)

**OPEN A - "Total Opening" command (terminal 1):** any pulse generator (push-button, detector, etc.) which, by closing a contact, commands total opening and/or closing of the gate leaf.

To install several total opening pulse generators, connect the N.O. contacts in parallel (see fig. 42).

**OPEN B - "Partial opening " or "Closing" command (terminal 2):** any pulse generator (push-button, detector, etc.) which, by closing a contact, commands partial opening and/or closing of the gate leaf. In the **B, C** and **B/C** logics, it always commands gate closure.

To install several partial opening pulse generators, connect the N.O. contacts in parallel (see fig. 42).

**FSW\_OP - Opening safety devices contact (terminal 3):** The purpose of the opening safety devices is to protect the leaf movement area during opening. During opening, in the **A-AP-S-E-EP** logics the safety devices reverse the movement of the gate leaves, or stop and restart the movement when they are released (see advanced programming in Par 5.2). During the opening cycle in logics **B, C** and **B/C**, they interrupt movement. They never operate during the closing cycle.

If the **Opening safety devices** are engaged when the gate is closed, they prevent the leaf opening movement.

To install several safety devices, connect the N.C. contacts in series (fig. 32).

**NB.: If no opening safety devices are connected, jumper connect inputs OP and -TX FSW (fig. 33).**

**FSW\_CL - Closing safety devices contact (terminal 4):** The purpose of the closing safety devices is to protect the leaf movement area during closing. During closing, in the **A-AP-S-E-EP** logics, the safety devices reverse the movement of the gate leaves, or stop and reverse the movement when they are released (see advanced programming in Par 5.2). During the closing cycle in logics **B, C** and **B/C**, they interrupt movement. They never operate during the opening cycle. If the **Closing safety devices** are engaged when the gate is open, they prevent the leaf closing movement.

To install several safety devices, connect the N.C. contacts in series (fig. 32).

**NB.: If no closing safety devices are connected, jumper connect terminals CL and -TX FSW (fig. 33).**

**STOP - STOP contact (terminal 5):** any device (e.g. a push-button) which, by opening a contact, is able to stop gate movement.

To install several STOP devices, connect the N.C. contacts in series.

**NB.: If STOP devices are not connected, jumper connect the STOP and - terminals.**

**EDGE - EDGE safety device contact (terminal 6):** The purpose of the "edge" safety device is to protect the leaf movement area during opening/closing against fixed obstacles (pillars, walls, etc.). In all logics, during opening and closing, the safety devices reverse gate leaf movement for 2 seconds. If the safety devices operate again during the 2-seconds reversing time, they STOP movement without any reversing. If the **Edge safety devices** are engaged while the gate is closed or open, they prevent the leaves movement.

To install several safety devices, connect the N.C. contacts in series (fig. 32).

**NB.: If edge safety devices are not connected, jumper connect the EDGE and - inputs. (fig. 33).**

- **Negative for power supply to accessories (terminals 7 and 8)**

+ **24 Vdc - Positive for power supply to accessories (terminals 9 and 10)**

**Important:** Accessories max. load is 500 mA. To calculate absorption values, refer to the instructions for individual accessories.

**TX -FSW - Negative for power supply to photocell transmitters (terminal 11)**

If you use this terminal for connecting the negative for supplying power to the photocell transmitters, you may, if necessary, also use the FAIL SAFE function (see advanced programming in par. 5.2).

If this function is enabled, the equipment checks operation of the photocells before every opening or closing cycle.

**W.L. - Power supply to indicator light / timed exit / electric lock / 'traffic lights' (terminal 12)**

Connect any 24 Vdc - 3 W max indicator light, timed exit, command device for electric lock or 'traffic lights' between this terminal and the +24V (see advanced programming in par. 5.2). To avoid jeopardising correct operation of the system, **do not exceed** the indicated power.

#### 4.5. Connector J2 - Rapid connection to Minidec, Decoder and RP

This is used for rapid connection of Minidec, Decoder and RP receivers (see fig. 43, 44, 45). Connect the accessory, with the components side facing the inside of the board. Insert and remove after cutting power.

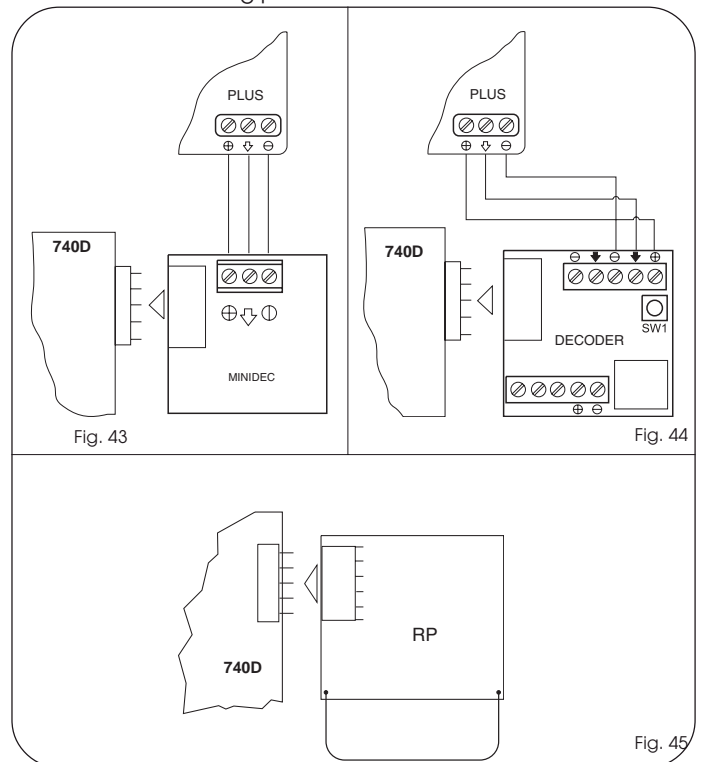

#### 4.6. Connector J6 - Limit-switches rapid connection (fig. 30)

This input is intended for rapid connection of the opening and closing limit-switches designed to stop the leaf, or for start of decelerations or for braking (see advanced programming in Par. 5.2.). In gearmotors with a built-in control unit, this connection is pre-wired as standard (fig. 30). For leaf opening direction, see advanced programming in Par 5.2.

#### 4.7. Connector J3 - Encoder rapid connection (fig. 30)

This input is designed for rapid connection of the Encoder (optional). To fit the encoder on the motor, refer to the relevant instructions.

The presence of the encoder is signalled - when the gearmotor is running - by the flashing of the "Encoder" LED on the board. When the encoder is used, the control unit knows the exact position of the gate while it is moving.

The encoder controls the adjustments of some of the control unit's functions in a different way (partial opening or deceleration - see advanced programming in Par 5.2) and as an anti-crushing device.

If the gate strikes an obstacle during opening or closing, the encoder immediately reverses the gate leaf for 2 seconds. If the encoder operates again during the 2 seconds reversing time, it STOPS movement without commanding any reversing.

## 5. PROGRAMMING

To program operation of the automated system, you have to access the "PROGRAMMING" mode.

Programming is split into two parts: *BASIC* and *ADVANCED*.

### 5.1. BASIC PROGRAMMING

To access BASIC PROGRAMMING, press key **F**:

- if you press it (and hold it down), the display shows the name of the first function.
- if you release the key, the display shows the value of the function that can be modified with keys **+** and **-**.
- if you press **F** again (and hold it down), the display shows the name of the next function, etc.
- when you reach the last function, press **F** to exit the program, and the display resumes showing the gate status.

The following table shows the sequence of functions accessible in BASIC PROGRAMMING:

BASIC PROGRAMMING		(F)
Display	Function	Default
LO	<b>FUNCTION LOGICS (see table of logics):</b> A = Automatic AP = "Stepped" automatic S = "Safety" Automatic E = Semi-automatic EP = "Stepped" Semi-automatic C = Dead-man b = "B" Semi-automatic b C = Mixed Log. (B opening / C closing)	EP
PA	<b>PAUSE TIME:</b> This has effect only if the automatic logic was selected. Adjustable from 0 to 50 sec. in one-second steps. Subsequently, display changes to minutes and tens of seconds (separated by a point) and time is adjusted in 10-second steps, up to the maximum value of 4.1 minutes.  E.g. if the display shows 2.5 pause time is 2 min. and 50 sec.	2.0
FO	<b>FORCE:</b> Adjusts Motor thrust. 01 = minimum force 50 = maximum force	50
d1	<b>OPENING DIRECTION:</b> Indicates the gate opening movement and makes it possible not to change the motor and limit-switches connections on the terminal board. - E = Right-hand opening movement E - = Left-hand opening movement	- E
SE	<b>STATUS OF AUTOMATED SYSTEM:</b> Exit from programming, save data, and return to gate status viewing. 00 = Closed 01 = Now opening 02 = At "STOP" 03 = Open 04 = Pause 05 = "FAIL SAFE" tripped 06 = Now closing 07 = Now reversing 08 = Photocells tripped	

### 5.2. ADVANCED PROGRAMMING

To access ADVANCED PROGRAMMING, press key **F** and, as you hold it down, press key **+**:

- if you release key **+**, the display indicates the name of the first function.
- if you release key **F** too, the display shows the value of the function that can be modified with keys **+** and **-**.
- if you press key **F** (and hold it down), the display shows the name of the next function, and if you release it, the value that can be modified with keys **+** and **-** is shown.
- when you reach the last function, press **F** to exit the program, and the display resumes showing the gate status.

The following table shows the sequence of functions accessible in ADVANCED PROGRAMMING:

ADVANCED PROGRAMMING		(F) + (+)
Display	Function	Default
bo	<b>MAXIMUM TORQUE AT INITIAL THRUST:</b> The motor operate at maximum torque (ignoring the torque setting) at start of movement. Useful for heavy leaves. y = Active no = Disabled	y
br	<b>FINAL BRAKING:</b> When the gate engages the opening or closing limit-switch, a braking stroke can be selected to ensure the leaf is stopped immediately. If decelerations are selected, braking starts when they finish. At 00 value, braking is disabled. Time can be adjusted from 01 to 20 in 0.01-second steps. 00 = Braking disabled from 01 to 20 = Timed braking	05
FS	<b>FAIL SAFE:</b> If this function is activated, it enables a function test of the photocells before any gate movement. If the test fails (photocells not serviceable signalled by value on the display), the gate does not start moving. y = Active no = Disabled	no
PF	<b>PRE-FLASHING (5 s):</b> Activates the flashing lamp for 5 seconds before start of movement. no = Disabled oP = Only before opening CC = Only before closing OC = Before every movement	no

Display	Function	Default
S P	<p><b>INDICATOR-LIGHT:</b> If 0 0 is selected, the output functions as a standard indicator-light (lighted at opening and pause, flashing at closing, and off when gate closed). <b>Courtesy light:</b> Different figures correspond to timed activation of the output, which can be used (by a relay) to power a courtesy lamp. Time can be adjusted from 1 to 5.9 sec. in 1-second steps, and from 1.0 to 4.1 min. in 10-second steps. <b>Electric lock command and 'traffic lights' functions:</b> If you press key - from the 0 0 setting, the command for the E 1 closing electric lock is activated; If you press - again, the command for the E 2 closing and opening electric lock is set; if you press the - key again, you can set the 'traffic lights' functions E 3 and E 4. 0 0 = Standard indicator-light from 0 1 to 4.1 = Timed output. E 1 = electric lock command before opening movement E 2 = electric lock command before opening and closing movements E 3 = 'traffic lights' function: the output is active in "open" and "open on pause" status and is disabled 3 seconds before the closing manoeuvre starts. Note: there is 3 seconds of pre-flashing before the closing manoeuvre. E 4 = 'traffic lights' function: the output is active only in "closed" status. <b>Attention: do not exceed the output's maximum load (24Vdc-3W). If necessary, use a relay and a power supply source outside the equipment.</b></p>	0 0
P h	<p><b>CLOSING PHOTOCELLS LOGIC:</b> Select the tripping mode of the closing photocells. They operate for the closing movement only: they stop movement and reverse it when they are released, or they reverse it immediately. y = Reverse on release n o = Reverse immediately to opening</p>	n o
o P	<p><b>OPENING PHOTOCELLS LOGIC:</b> Select the tripping mode of the opening photocells. They operate for the opening movement only: they stop the movement and restart it when they are released, or they reverse it immediately. y = Reverse immediately to closing n o = Restart movement on release</p>	n o

Display	Function	Default
E C	<p><b>ENCODER:</b> If the encoder is used, you may select its presence. If the encoder is present and enabled, "decelerations" and "partial opening" are controlled by the encoder (see relevant paragraphs). The encoder operates as an anti-crushing device: If the gate strikes an obstacle during opening or closing, the encoder immediately reverses gate leaf movement for 2 seconds. If the encoder operates again during the 2-seconds reversing time, it stops movement (STOP) without commanding any reversing. If no sensor is supplied, the parameter must be set on 0 0. If there is the encoder, adjust the sensitivity of the anti-crushing system, by varying the parameter between 0 1 (maximum sensitivity) and 9 9 (minimum sensitivity).  from 0 1 to 9 9 = Encoder active and sensitivity adjustment 0 0 = Encoder disabled</p>	0 0
r P	<p><b>Pre-limit switch DECELERATION:</b> You can select gate deceleration before the opening and closing limit-switches have been tripped. Time can be adjusted from 0 0 to 9 9 in 0.04-second steps. If an encoder is used, the adjustment is not determined by time but by motor revs, thus obtaining greater deceleration precision.  0 0 = Deceleration disabled from 0 1 to 9 9 = Deceleration enabled</p>	0 0
r A	<p><b>Post-limit switch DECELERATION:</b> You can select gate deceleration after the opening and closing limit-switches have been tripped. Time can be adjusted from 0 0 to 2 0 in 0.02-second steps. If an encoder is used, the adjustment is not determined by time but by motor revs, thus obtaining greater deceleration precision.  0 0 = Deceleration disabled from 0 1 to 2 0 = Deceleration enabled</p>	0 5
P O	<p><b>PARTIAL OPENING:</b> You can adjust the width of partial leaf opening. Time can be adjusted from 0 1 to 2 0 in 1-second steps. If an encoder is used, the adjustment is not determined by time but by motor revs, thus obtaining greater partial-opening precision. For example, with pinion Z20, partial opening can vary from about 60 cm to 4 m.</p>	0 5

Display	Function	Default
E	<p><b>WORK TIME (time-out):</b> We advise you to set a value of 5 to 10 seconds over the time taken by the gate to travel from the closing limit-switch to the opening limit-switch and vice versa. Adjustable from 0 to 59 sec. in one-second steps. Subsequently, display changes to minutes and tens of seconds (separated by a point) and time is adjusted in 10 second steps, up to a maximum value of 4.1 minutes.</p> <p><b>Attention: the set value does not exactly match the motor's maximum operating time, because the latter is modified according to the performed deceleration spaces.</b></p>	4.1
AS	<p><b>ASSISTANCE REQUEST (combined with next function):</b> If activated, at the end of countdown (settable with the next function i.e. "Cycle programming") it effects 2 sec. (in addition to the value already set with the PF function) of pre-flashing at every Open pulse (job request). Can be useful for setting scheduled maintenance jobs. y = Active no = Disabled</p>	no
nc	<p><b>CYCLE PROGRAMMING:</b> For setting countdown of system operation cycles. Settable (in thousands) from 00 to 99 thousand cycles. The displayed value is updated as cycles proceed. This function can be used to check use of the board or to exploit the "Assistance request".</p>	00
SE	<p><b>GATE STATUS:</b> Exit from programming, data saving, and return to viewing gate status (see par. 5.1.).</p>	

**NB.:** modification of programming parameters comes into effect immediately, whereas definitive memory storage occurs only when you exit programming and return to gate status viewing. If the equipment is powered down before return to status viewing, all modifications will be lost.

To restore the default settings of the programming disconnect terminal strip J1, press the three buttons +, -, F simultaneously and keep them pressed for 5 seconds.

## 6. START-UP

### 6.1. INPUTS CHECK

The table below shows the status of the LEDs in relation to the status of the inputs.

Note the following: **LED LIGHTED** = closed contact

**LED OFF** = open contact

Check the status of the LEDs as per Table.

#### Operation of the signalling status LEDs

LEDS	LIGHTED	OFF
FCA	Limit-switch free	Limit-switch engaged
FCC	Limit-switch free	Limit-switch engaged
OPEN B	Command activated	Command inactive
OPEN A	Command activated	Command inactive
FSW OP	Safety devices disengaged	Safety devices engaged
FSW CL	Safety devices disengaged	Safety devices engaged
STOP	Command inactive	Command activated
EDGE	Safety devices disengaged	Safety devices engaged

**NB.:**

- The status of the LEDs while the gate is closed at rest are shown in bold.

## 7. FINAL OPERATIONS

At end of programming, run a few complete cycles to check if the automated system and the accessories connected to it are operating correctly, giving special attention to safety devices, operator thrust force adjustment, and to the anti-crushing device (Encoder sensor, optional). Hand over the "User's guide" page (in the operator instructions) to the customer, and describe how the system works, as well as the operator release and locking operations indicated in the said guide.

Tab. 3/a

PULSES						
Logic "A"	OPEN-A	OPEN-B	STOP	OPENING SAFETY DEVICES	CLOSING SAFETY DEVICES	EDGE SAFETY DEVICE
<b>GATE STATUS</b>						
<b>CLOSED</b>	Opens the leaf and closes it after pause time (1)	Opens leaf for the partial opening time and closes after pause time (1)		No effect (OPEN disabled)	No effect	No effect (OPEN disabled)
<b>OPEN on PAUSE</b>	Reloads pause time (1)(3)			No effect (if on part.opng. OPEN A disabled)	Reloads pause time (1) (3)	Reloads pause time (1) (OPEN disabled)
<b>CLOSING</b>	Re-opens the leaf immediately (1)		Stops operation	No effect (saves OPEN)	see paragraph 5.2.	Reloads pause time (1) (OPEN disabled) Reverses to open for 2" (2)
<b>OPENING</b>	No effect (1) (3)			see paragraph 5.2.	No effect	Reverses to close for 2" (2)
<b>LOCKED</b>	Closes the leaf (3)		No effect (OPEN disabled)	No effect	No effect	No effect (OPEN disabled)

Tab. 3/b

PULSES						
Logic "AP"	OPEN-A	OPEN-B	STOP	OPENING SAFETY DEVICES	CLOSING SAFETY DEVICES	EDGE SAFETY DEVICE
<b>GATE STATUS</b>						
<b>CLOSED</b>	Opens the leaf and closes it after pause time	Opens leaf for the partial opening time and closes after pause time		No effect (OPEN disabled)	No effect	No effect (OPEN disabled)
<b>OPEN on PAUSE</b>	Stops operation (3)			No effect (if on part.opng. OPEN A disabled)	Reloads pause time (3) (OPEN disabled)	Reloads pause time (OPEN disabled)
<b>CLOSING</b>	Re-opens the leaf immediately		Stops operation	No effect (saves OPEN)	see paragraph 5.2.	Reverses to open for 2" (2)
<b>OPENING</b>	Stops operation (3)			see paragraph 5.2.	No effect	Reverses to close for 2" (2)
<b>LOCKED</b>	Closes the leaf (with Closing Safety devices engaged, opens at the 2nd pulse) (3)		No effect (OPEN disabled)	No effect	No effect	No effect (OPEN disabled)

Tab. 3/c

PULSES						
Logic "S"	OPEN-A	OPEN-B	STOP	OPENING SAFETY DEVICES	CLOSING SAFETY DEVICES	EDGE SAFETY DEVICE
<b>GATE STATUS</b>						
<b>CLOSED</b>	Opens the leaf and closes it after pause time	Opens leaf for the partial opening time and closes after pause time		No effect (OPEN disabled)	No effect	No effect (OPEN disabled)
<b>OPEN on PAUSE</b>	Re-closes the leaf immediately (3)			No effect (if on part.opng. OPEN A disabled)	On release, closes after 5" (OPEN disabled) (3)	Reloads pause time (1) (OPEN disabled)
<b>CLOSING</b>	Re-opens the leaf immediately		Stops operation	No effect (saves OPEN)	see paragraph 5.2.	Reverses to open for 2" (2)
<b>OPENING</b>	Re-closes the leaf immediately (3)			see paragraph 5.2.	No effect (saves OPEN)	Reverses to close for 2" (2)
<b>LOCKED</b>	Closes the leaf (3)		No effect (OPEN disabled)	No effect	No effect	No effect (OPEN disabled)

Tab. 3/d

PULSES						
Logic "E"	OPEN-A	OPEN-B	STOP	OPENING SAFETY DEVICES	CLOSING SAFETY DEVICES	EDGE SAFETY DEVICE
<b>GATE STATUS</b>						
<b>CLOSED</b>	Opens the leaf	Opens leaf for the partial opening time		No effect (OPEN disabled)	No effect	No effect (OPEN disabled)
<b>OPEN</b>	Re-closes the leaf immediately (3)			No effect (if on part.opng. OPEN A disabled)	No effect (3) (OPEN disabled)	No effect (OPEN disabled)
<b>CLOSING</b>	Re-opens the leaf immediately		Stops operation	No effect (saves OPEN)	see paragraph 5.2.	Reverses to open for 2" (2)
<b>OPENING</b>	Stops operation (3)			see paragraph 5.2.	No effect	Reverses to close for 2" (2)
<b>LOCKED</b>	Closes the leaf (with Closing Safety devices engaged, opens at the 2nd pulse) (3)		No effect (OPEN disabled)	No effect	No effect	No effect (OPEN disabled)

PULSES						
Logic "EP"	OPEN-A	OPEN-B	STOP	OPENING SAFETY DEVICES	CLOSING SAFETY DEVICES	OP/CL SAFETY DEVICE
<b>GATE STATUS</b>						
<b>CLOSED</b>	Opens the leaf	Opens leaf for the partial opening time		No effect (OPEN disabled)	No effect	No effect (OPEN disabled)
<b>OPEN</b>	Re-closes the leaf immediately (3)		Stops operation	No effect (if on part. opening, OPEN A disabled)	No effect (OPEN disabled) (3)	No effect (OPEN disabled)
<b>CLOSING</b>	Stops operation	Stops operation		No effect (saves OPEN)	see paragraph 5.2.	Locks and, on release, reverses to open
<b>OPENING</b>	Stops operation (3)	Stops operation (3)		see paragraph 5.2.	No effect	Locks and, on release, continues opening
<b>LOCKED</b>	Restarts movement in reverse direction (3) (always closes after a Stop)		No effect (OPEN disabled)	No effect (if it must open, it disables OPEN)	No effect (if it must close, it disables OPEN)	No effect (OPEN disabled)

Tab. 3/f

PULSES						
CONTROLS ALWAYS HELD DOWN						
Logic "C"	OPEN-A (opening)	OPEN-B (closing)	STOP	OPENING SAFETY DEVICES	CLOSING SAFETY DEVICES	OP/CL SAFETY DEVICE
<b>GATE STATUS</b>						
<b>CLOSED</b>	Opens the leaf	No effect (OPEN-A disabled)		No effect (OPEN A disabled)	No effect	No effect (OPEN A disabled)
<b>OPEN</b>	No effect (OPEN-B disabled)	Closes the leaf	No effect (OPEN-A/B disabled)	No effect (OPEN A disabled)	No effect (OPEN B disabled)	No effect (OPEN-A/B disabled)
<b>CLOSING</b>	Stops operation	/	Stops operation	No effect	Stops operation (OPEN-B disabled)	Stops operation (OPEN-A/B disabled)
<b>OPENING</b>	/	Stops operation		Stops operation (OPEN-A disabled)	No effect	Reverses to open for 2" (2)
						Reverses to close for 2" (2)

Tab. 3/g

PULSES						
Logic "B"	OPEN-A (opening)	OPEN-B (closing)	STOP	OPENING SAFETY DEVICES	CLOSING SAFETY DEVICES	OP/CL SAFETY DEVICE
<b>GATE STATUS</b>						
<b>CLOSED</b>	Opens the leaf	No effect		No effect (OPEN A disabled)	No effect	No effect (OPEN A disabled)
<b>OPEN</b>	No effect	Closes the leaf	No effect (OPEN B disabled)	No effect	No effect (OPEN B disabled)	No effect (OPEN-A/B disabled)
<b>CLOSING</b>	Reverses to open	No effect	Stops operation	No effect (saves OPEN A)	Stops operation (OPEN-B disabled)	Stops operation (OPEN-A/B disabled)
<b>OPENING</b>	No effect	No effect	Stops operation	Stops operation (OPEN-A disabled)	No effect	Reverses to open for 2" (2)
<b>LOCKED</b>	Opens the leaf	Closes the leaf	No effect (OPEN A/B disabled)	No effect (OPEN-A disabled)	No effect (OPEN B disabled)	Reverses to close for 2" (2)

Tab. 3/h

PULSES						
OPENING PULSE/CLOSING HOLD TO RUN CONTROLS						
Logic "B/C"	OPEN-A (opening)	OPEN-B (closing)	STOP	OPENING SAFETY DEVICES	CLOSING SAFETY DEVICES	OP/CL SAFETY DEVICE
<b>GATE STATUS</b>						
<b>CLOSED</b>	Opens the leaf	No effect		No effect (OPEN A disabled)	No effect	No effect (OPEN A disabled)
<b>OPEN</b>	No effect	Closes the leaf	No effect (OPEN B disabled)	No effect	No effect (OPEN B disabled)	No effect (OPEN-A/B disabled)
<b>CLOSING</b>	Reverses to open	No effect	Stops operation	No effect (saves OPEN A)	Stops operation (OPEN-B disabled)	Stops operation (OPEN-A/B disabled)
<b>OPENING</b>	No effect	No effect	Stops operation	Stops operation (OPEN-A disabled)	No effect	Reverses to open for 2" (2)
<b>LOCKED</b>	Opens the leaf	Closes the leaf	No effect (OPEN A/B disabled)	No effect (OPEN-A disabled)	No effect (OPEN B disabled)	Reverses to close for 2" (2)

(1) If maintained, it prolongs the pause until disabled by the command (timer function)  
 (2) If a new pulse occurs within 2 seconds after reversing, it immediately stops operation.

(3) During the partial opening cycle, an OPEN A pulse causes total opening.  
 NB.: Effects on other active pulse inputs in brackets.

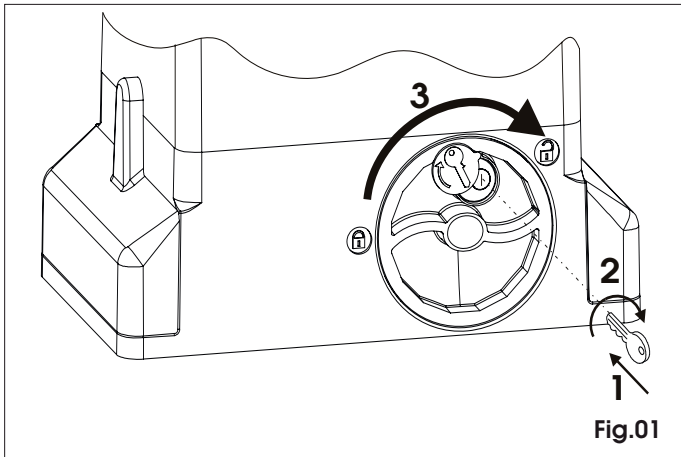

Fig.01

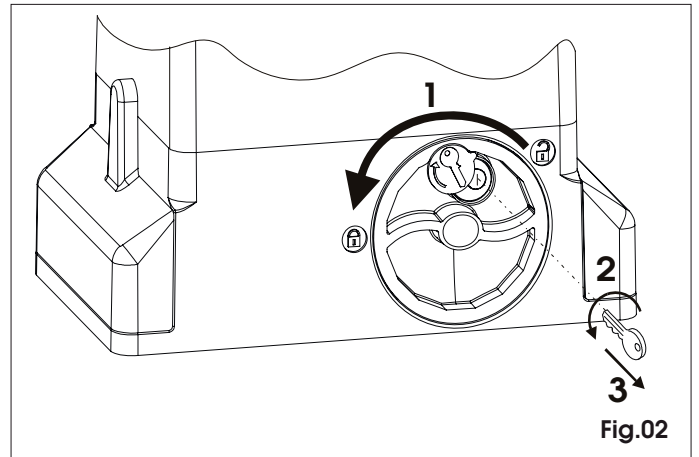

Fig.02

### AUTOMATED SYSTEM 740-741

Read the instructions carefully before using the product and keep them for future consultation.

#### GENERAL SAFETY RULES

If installed and used correctly, the 740-741 automated system will ensure a high degree of safety.

Some simple rules regarding behaviour will avoid any accidental trouble:

- Do not stand near the automated system and do not allow children and other people or things to stand there, especially while it is operating.
- Keep radiocontrols or any other pulse generator well away from children to prevent the automated system from being activated involuntarily.
- Do not allow children to play with the automated system.
- Do not willingly obstruct gate movement.
- Prevent any branches or shrubs from interfering with gate movement.
- Keep light signalling systems efficient and clearly visible.
- Do not attempt to activate the gate by hand unless you have released it.
- In the event of malfunctions, release the gate to allow access and wait for qualified technical personnel to do the necessary work.
- After enabling manual operation, switch off the power supply to the system before restoring normal operation.
- Do not make any alterations to the components of the automated system.
- Do not attempt any kind of repair of direct action whatsoever and contact qualified personnel only.
- Call in qualified personnel at least every 6 months to check the efficiency of the automated system, safety devices and earth connection.

#### DESCRIPTION

The 740-741 automated system is ideal for controlling vehicle access areas of medium transit frequency.

The 740-741 automated system for sliding gates is an electro-mechanical operator transmitting motion to the sliding gate via a rack pinion or chain appropriately coupled to the gate.

Operation of the sliding gate is controlled by an electronic control unit housed inside the operator or in a hermetically sealed outdoor enclosure.

When, with the gate closed, the unit receives an opening command by radiocontrol or from another suitable device, it activates the motor until the opening position is reached.

If automatic operation was set, the gate re-closes automatically after the selected pause time has elapsed.

If the semi-automatic operation was set, a second pulse must be sent to close the gate again.

An opening pulse during re-closing, always causes movement to be reversed.

A stop pulse (if provided) always stops movement.

The light signalling indicates that the gate is currently moving.

For details on sliding gate behaviour in different function logics, consult the installation technician.

The automated systems include obstacle-detection and/or safety devices (photocells, edges) that prevent the gate from closing when

there is an obstacle in the area they protect.

The system ensures mechanical locking when the motor is not operating and, therefore, it is not necessary to install any lock.

Manual opening is, therefore, only possible by using the release system. The gearmotor does not have a mechanical clutch and, therefore, it is coupled to a unit with an electronic clutch offering the necessary anti-crushing safety if the system is completed with the necessary safety devices.

A convenient manual release with customised key makes it possible to move the gate in the event of a power failure or malfunction.

#### MANUAL OPERATION

**Warning:** Cut power to the system to prevent an involuntary pulse from activating the gate during the release manoeuvre.

To release the operator proceed as follows:

- 1) Insert the key provided and turn it clockwise as shown in Fig. 01 ref. 1 and 2.
- 2) Turn the release system clockwise, until the mechanical stop is reached, Fig. 01 ref. 3.
- 3) Open and close the gate manually.

#### RESTORING NORMAL OPERATION

**Warning:** Cut power to the system to prevent an involuntary pulse from activating the gate during the manoeuvre for restoring normal operation.

To restore normal operation proceed as follows:

- 1) Turn the release system anti-clockwise, until its stop is reached, Fig. 02 ref. 1.
- 2) Turn the key anti-clockwise and remove it from the lock, Fig. 02 ref. 2 and 3.
- 3) Move the gate until the release system meshes (corresponds to gate locking).
- 4) Power up the system.

#### MAINTENANCE

To ensure trouble-free operation and a constant safety level, an overall check of the system should be carried out every 6 months. A form for recording routine maintenance operations is enclosed.

#### REPAIRS

For any repairs, contact the authorised Repair Centres.

#### AVAILABLE ACCESSORIES

Refer to catalogue for available accessories.





The descriptions and illustrations contained in this manual are not binding. FAAC reserve the right, whilst leaving the main features of the main equipment unaltered, to undertake any modifications it holds necessary for either technical or commercial reasons, at any time and without revising the present publication.

FAAC (UK) Limited, 6 Hamilton Close  
Houndmills Estate, Basingstoke, RG21 6YT  
Telephone: 01256 318100  
Fax: 01256 318101  
Email: sales@faac.co.uk  
Website: www.faac.co.uk

V5 01/07

**SINCERT**



Your authorised FAAC dealer